

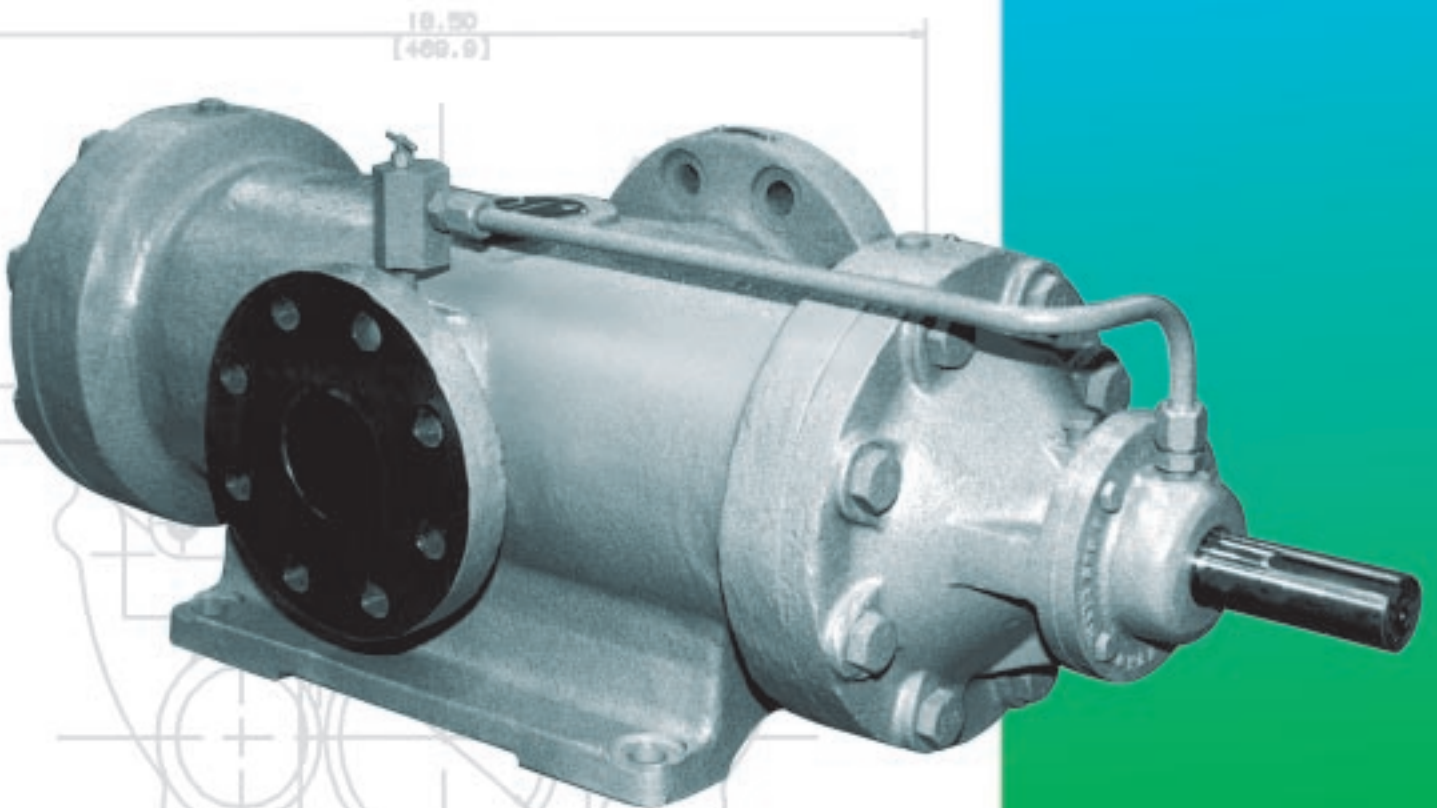

324A SERIES THREE SCREW PUMPS



ROTARY SCREW PUMPS

The reliable pump people

Performance Shown at 250 PSID (17 BAR), 200 SSU (43 CST)

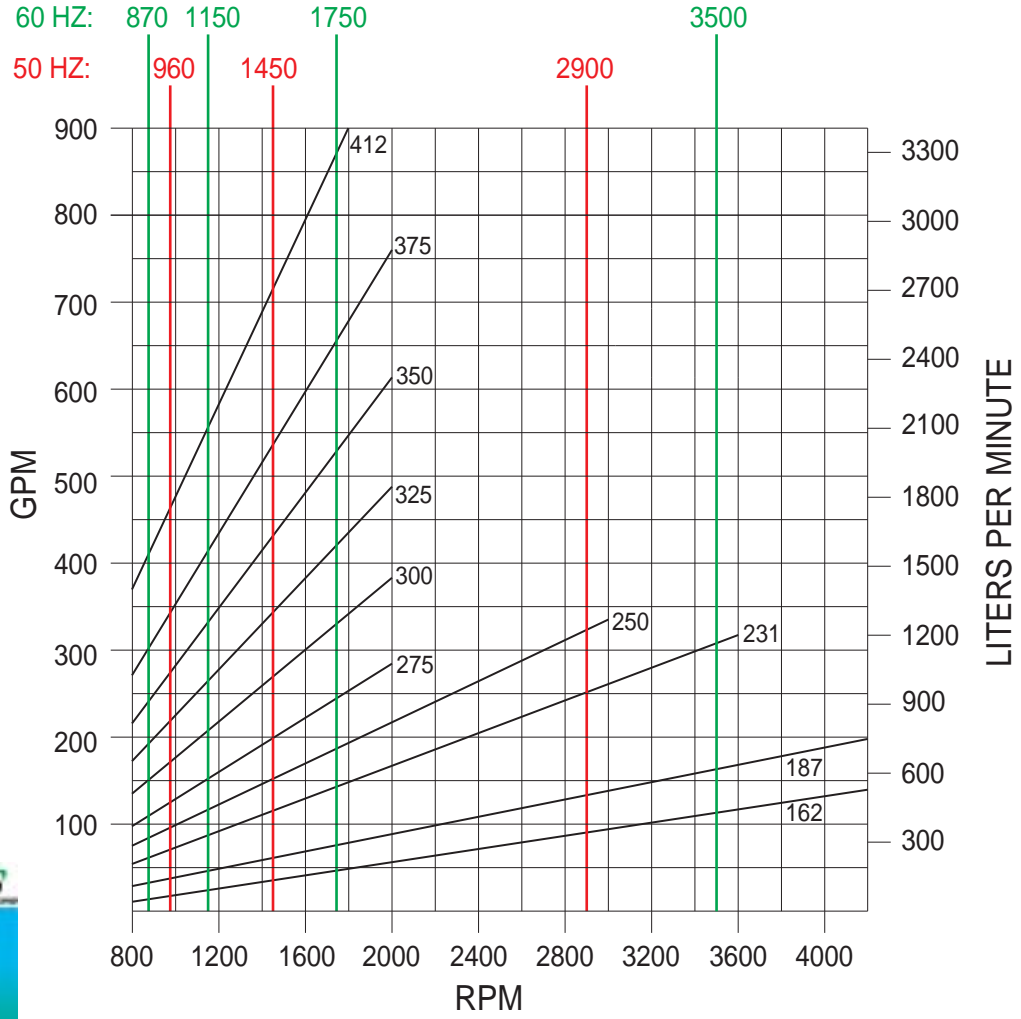

On the cover...324A cast iron cased horizontal pump.



Steel cased 324A pump with fabricated steam jacket



Magnetic drive 324A pump for up to 200 HP (150 KW) at 3500 RPM

Imo Series C324A Pump

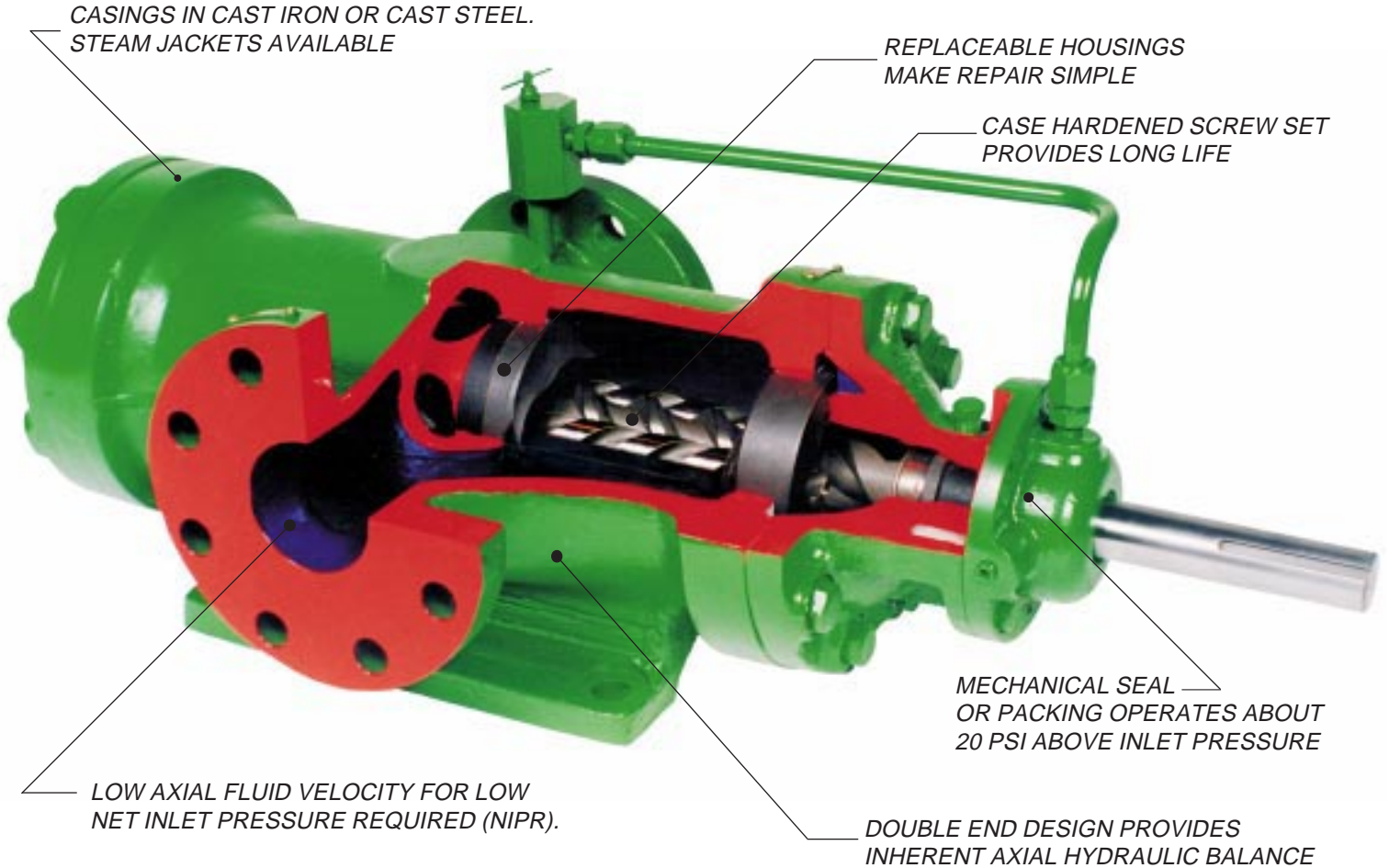

Model Code Example:

C324A B T F S -187

<p>Series</p> <p>Shaft Seal and Bearing Type</p> <p>E = High Temperature Packing</p> <p>B = Buna Fitted Mechanical Seal</p> <p>H = Fluoroelastomer Fitted Mechanical Seal</p> <p>Mechanical Seal Seat</p> <p>Blank = Standard Seat (Type B and H only)</p> <p>T = Carbide Seal Seat (Type B and H only)</p> <p>Mounting</p> <p>F = Foot Mount</p> <p>V = Vertical Mount (Consult Imo)</p>	<p>Rotation</p> <p>Blank = Clockwise</p> <p>D = Counterclockwise</p> <p>Rotor Size</p> <p>162 through 412</p> <p>Casing</p> <p>Blank = Cast Iron</p> <p>S = Steel</p> <p>J = Steam Jacketed Steel Case</p> <p>Y = Steam Jacket Steel Case and Packing Cover</p>
---	---

Specifications

Casing	High tensile, close-grained cast iron. Optional cast steel. Steam jacket available on steel cased pump, 150 PSIG (10 BAR) maximum jacket pressure.
Rotor Housings	Pearlitic gray iron.
Rotors	Alloy steel, ground and nitride hardened.
Gaskets	Cellulose and non-asbestos fiber.
Shaft Seal and Bearing	Type E: High temperature packing for steel cased pumps. Type B: Buna N bellows mechanical seal for lighter duties. Type H: Positive drive mechanical seal with fluoroelastomer o-rings for higher viscosities or temperatures. All pumps use in internal cast iron bushing. Sealless magnetic drive pumps also available.
Outlet Pressure	500 PSIG (34.5 BAR) maximum.
Inlet Pressure	25 PSIG (1.7 BAR) maximum for single extended shaft. 50 PSIG (3.4 BAR) maximum for double extended shaft.
Viscosity	Type E 100 - 25,000 SSU (20-5400 CST) – recommended for residual and crude oils. Type B: 50-3000 SSU (8-650 CST) – recommended for light duty, non-abrasive lube and hydraulic oils. Type H: 50-20,000 SSU (8-4300 CST) – recommended for viscosities above 3000 SSU (650 CST), all residual oils and heavy crude oils.
Temperature	Type E: Cast iron case, 0 to 400°F (-18 to 204°C) Type E: Steel case, 0 to 500°F (-18 to 260°C) Type B: 0 to 180°F (-18 to 82°C) Type H: 0 to 400°F (-18 to 204°C) <i>Special mechanical seal versions available to 500°F (260°C)</i>
Speed	Maximum speeds indicated by curve termination.
Drive	Direct only. Double extended shaft versions available for through-drives. Sealless magnetic drives also available. Consult Imo.
Rotation	Clockwise facing pump shaft. Counterclockwise optional on sizes 187 thru 250.
Mounting	May be foot mounted in any attitude. Optional vertical mounting available for certain applications. Consult Imo.
Accessories	Completely mounted pump/driver assemblies with baseplates, etc. built to order are available.
Filtration	Inlet strainers are required to keep contaminants and abrasives out of the pump. They must be selected in consultation with the strainer vendor to prevent pump starvation. Normally, 60 mesh (0.01 inch- 238 micron) for light and 1/8-3/16 inch (3-5mm) openings for heavy oils are recommended.

50-900 GPM (1909-3400 L/M) Pressure to 500 PSIG (34 BAR)

Series C324A pumps are of the double suction design. They are inherently in axial hydraulic balance due to the symmetry of the flows. Because this pump series is essentially two pumps operating in parallel, the pumps are very compact for their flow range. 324A pumps are especially suitable for higher temperature operation (asphalts, vacuum tower bottoms, etc.) as there are no antifriction bearings requiring separate cooling. In addition, this series is capable of relatively high speeds making it ideal for steam turbine drive where high speeds improves the efficiency of both the driver and the pump.

Several pump sizes are available in corrosion resistant construction for polymer processing at very high viscosities. Other units are available in through-drive configurations allowing a second pump or other device to be driven from the end opposite the drive end. Series 324A is also available in sealless magnetic drive designs. Consult Imo to select the pump best suited for your application.

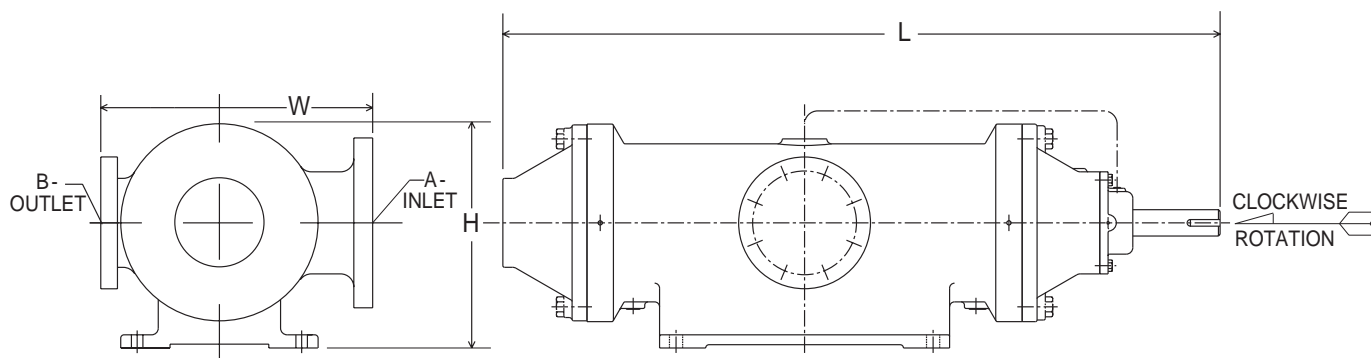

IRON CASED PUMPS HAVE 250# ANSI FLAT FACED FLANGES
STEEL CASED PUMPS HAVE 300# ANSI FLAT FLANGES

Size	A		B		H		L		W		WEIGHT	
	INCH	MM	INCH	MM	INCH	MM	INCH	MM	INCH	MM	LBS.	KG
162/187	3	76	2 1/2	64	9 3/4	248	31 1/4	794	11 3/4	299	305	139
231/250	4	102	3	76	12 1/8	308	37 1/8	943	15	381	480	218
275/300	5	127	4	102	12 13/16	326	50 11/16	1288	18	458	850	386
325/350	5	127	4	102	17	432	54 7/8	1394	20-1/2	521	1100	500
375/412	6	152	5	127	17 1/2	445	61 1/8	1553	21	534	1450	659

Imo Pump Sales Offices

Houston

Imo Pump
11811 N. Freeway
Suite 190
Houston, TX 77060

tel 281.448.1337

fax 281.445.2316

New Orleans

Imo Pump
2637 Edenborn Avenue
Suite 304
Metairie, LA 70002

tel 504.888.3333

fax 504.888.3337

Philadelphia

Imo Pump
515 Stump Road
Suite 222
North Wales, PA 19454

tel 215.393.7400

fax 215.393.7622

Calgary

Imo Pump
5918 5th Street, S.E.
Unit 14
Calgary, Alberta
Canada T2H 1L4

tel 403.253.7491

fax 403.252.9833

Toronto

Imo Pump
6750 Davand Drive
Units 9/209
Mississauga, Ontario
Canada L5T 1L8

tel 905.564.3344

fax 905.564.3577

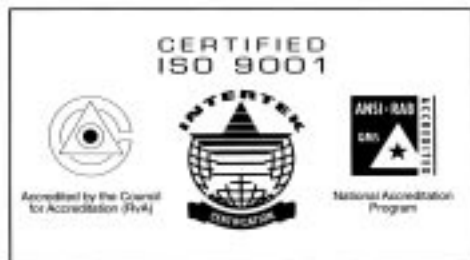

Quality Management System



Imo Pump
1710 Airport Road
PO Box 5020
Monroe, NC USA
28111.5020

tel 704.289.6511

fax 704.289.9273

email IMOPUMP@VNET.NET

web WWW.IMO-PUMP.COM