

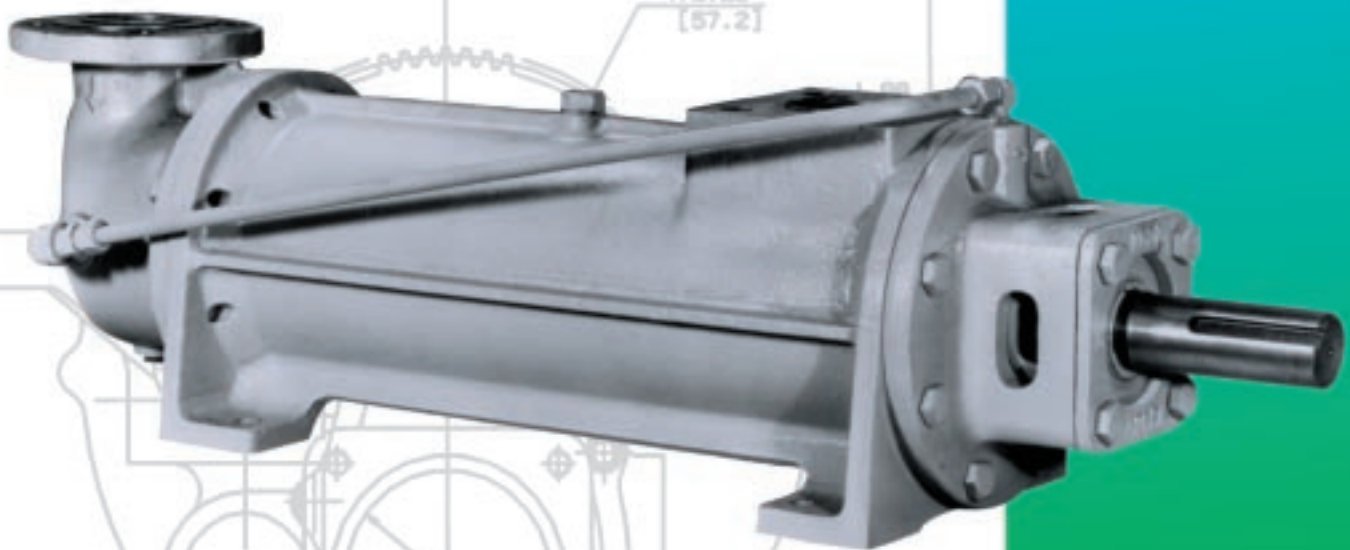

# 6D SERIES THREE SCREW PUMPS



***The reliable pump people***

**ROTARY SCREW PUMPS**

# Performance Shown at 1000 PSID (70 BAR), 200 SSU (43 CST)

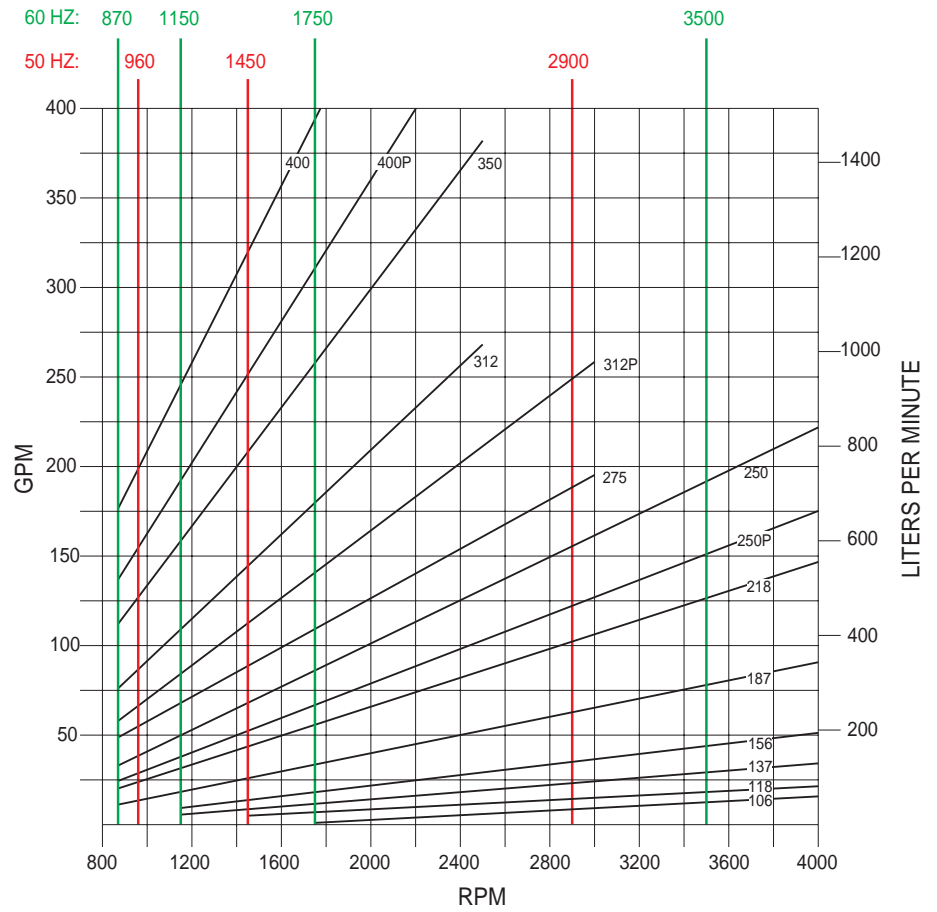

On the cover...6D-250 pump typical for sizes 218-400 shown with standard (top) inlet position. Outlet socket weld adapter is included with pump.

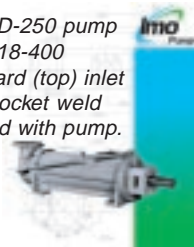

(16) 6D-312 pumps on crude oil pipeline service in the Pacific Rim area

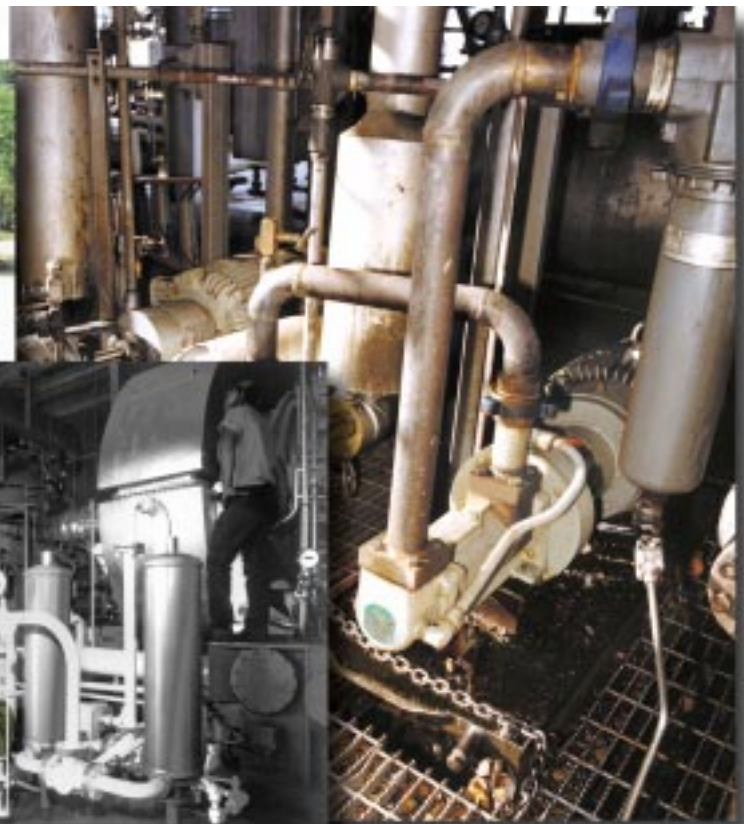

6D-118 pump on pipeline turbo compressor gas sealing service

Sealless Mag drive 6D-156 pump on turbo expander gas sealing service



# Specifications

---

<b>Casing</b>	High shock capacity ductile (nodular) iron. Consult Imo for steel case availability.
<b>Rotor Housing</b>	Pearlitic gray iron for rotor sizes 106 through 187; bronze sizes 218 and larger.
<b>Power Rotor</b>	Alloy steel, nitride hardened and thread ground.
<b>Idler Rotors</b>	Pearlitic gray iron, induction hardened and thread ground for sizes 106 through 187; alloy steel, nitride hardened and thread ground sizes 218 and larger.
<b>Gaskets</b>	Cellulose and non-asbestos fiber.
<b>Seal &amp; Bearing</b>	Type B: Buna N bellows mechanical seal, Buna N O-rings and standard external, permanently grease packed, deep groove ball bearing – recommended for distillate fuels and lubricating oil or hydraulic fluids. Type H: Positive drive mechanical seal, fluorocarbon O-rings and external high temperature, permanently grease packed, deep groove ball bearing. Sealless magnetic drive also available.
<b>Accessories</b>	Completely mounted, built to order pump/driver assemblies are available with baseplates, ANSI RF spool pieces, NEMA 'C' face adapters.
<b>Outlet Pressure</b>	1500 PSIG (103 BAR) maximum for lube, seal and hydraulic oils. 1000 PSIG (70 BAR) maximum for distillate, residual and crude oils. Minimum recommended differential pressure is 40 PSI (2.8 BAR).
<b>Inlet Pressure</b>	Type B & H: 75 PSIG (5 BAR) maximum, sizes 106-187 50 PSIG (3 BAR) maximum, sizes 218-400
<b>Viscosity</b>	33 SSU (2.0 CST) minimum Type B: 3000 SSU (650 CST) maximum (consider cold start) Type H: Viscosities above 3000 SSU (650 CST)
<b>Temperature</b>	Type B: 0 to 180°F (-18 to 82°C) Type H: Sizes 106-187: 0 to 250°F (-18 to 121°C) for <1800 RPM 0 to 225°F (-18 to 107°C) for > 1800 RPM Sizes 218 and up: 0 to 200°F (-18 to 93°C)
<b>Speed</b>	See curve termination for maximum speed. Do not exceed 1800 RPM when pumping residual fuels or crude oil due to the presence of abrasives and contaminants.
<b>Drive</b>	Direct only. Magnetic drive also available to 200 HP at 3500 RPM.
<b>Rotation</b>	Clockwise facing pump shaft.
<b>Mounting</b>	May be foot mounted in any orientation. Flange mounting optional for certain applications.
<b>Filtration</b>	Inlet strainers are required to keep contaminants and abrasives out of the pump. They must be selected in consultation with the strainer vendor to prevent pump starvation. Normally, 60 mesh (0.01 inch- 238 micron) for light and 1/8-3/16 inch (3-5mm) openings for heavy oils are recommended.

---

# 4-400 GPM (16-1514 L/M) Pressure to 1500 PSIG (103 BAR)

Series 6D lmo pumps are intended for relatively high pressure service on petroleum or similar viscosity liquids. Typical applications include crude oil pipeline service, fuel atomization for burning in a steam boiler, fuel injection for combustion gas turbines, fluid power service on hydraulically operated machinery, gas sealing in centrifugal compressors and hydrostatic bearing support.

These pumps are hydraulically balanced in both the axial and radial directions which eliminates bearing loads due to discharge pressure. The single bearing is external to the liquid pumped and does not rely on the lubricating qualities of the pumped liquid. The single mechanical seal is exposed only to inlet pressure. Very low airborne noise levels are normal for lmo three screw positive displacement pumps as are high operating efficiencies and non-pulsating delivery of flow.

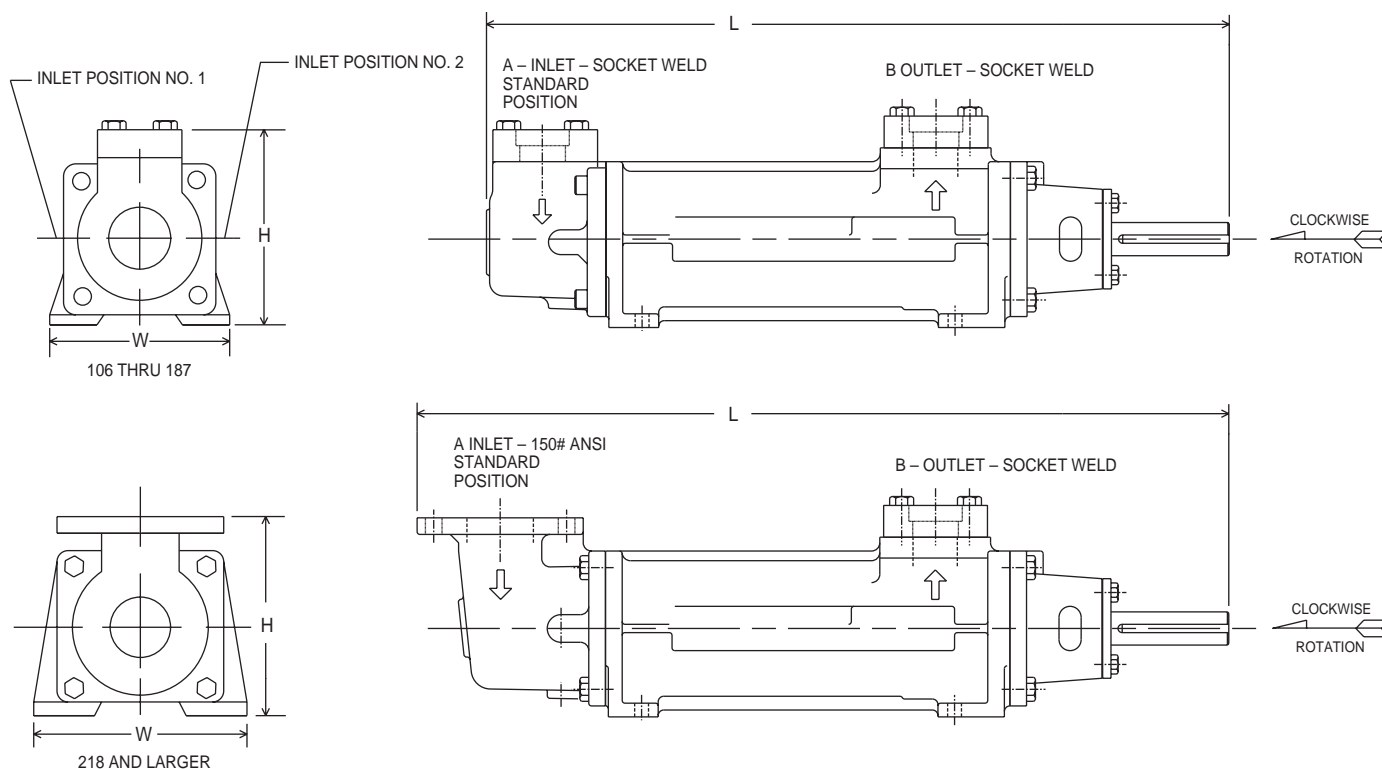

SIZE	A		B		H		L		W		WEIGHT	
	INCH	MM	INCH	MM	INCH	MM	INCH	MM	INCH	MM	LBS.	KG
106	1	25.4	1	25.4	6.8	172	18.4	468	6	153	49	22.2
118	1-1/2	38.1	1	25.4	7	189	19.6	498	6.3	161	57	25.9
137	1-1/2	38.1	1	25.4	7.3	185	21.7	552	6.5	166	71	32.2
156	2	50.8	1-1/2	38.1	7.8	197	24.2	615	7	178	83	37.7
187	2	50.8	1-1/2	38.1	8.3	210	26.5	674	7.5	191	117	53
218	2-1/2	63.5	2	50.8	9	244	36.5	928	9	228	204	93
250	3	76.2	2-1/2	63.5	10.75	280	39.9	1014	10	254	309	140
275	3	76.2	3	76.2	11.12	313	42	1067	11	280	350	159
312	4	101.6	3	76.2	11.75	331	46	1169	12	305	392	177
350	5	127	4	101.6	13.25	412	50.4	1281	13	331	510	231
400	6	152.4	4	101.6	16	432	55	1397	14	356	845	383

# The Reliable Pump People



A Member of the  
COLFAX PUMP GROUP

## Imo Pump

1710 Airport Road  
PO Box 5020  
Monroe, NC  
28111.5020  
USA

tel +1 (704) 289 6511  
fax +1 (704) 289 9273

E-mail  
Imo.Pump@ColfaxCorp.com  
Internet  
<http://www.imo-pump.com>



ALLWEILER



HOUTTUIN



IMO PUMP



WARREN



**COLFAX PUMP GROUP**

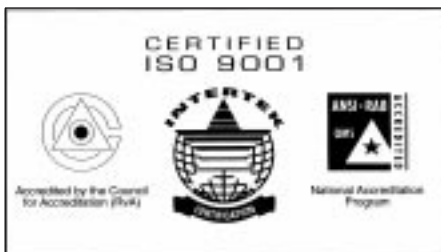

Quality Management System