

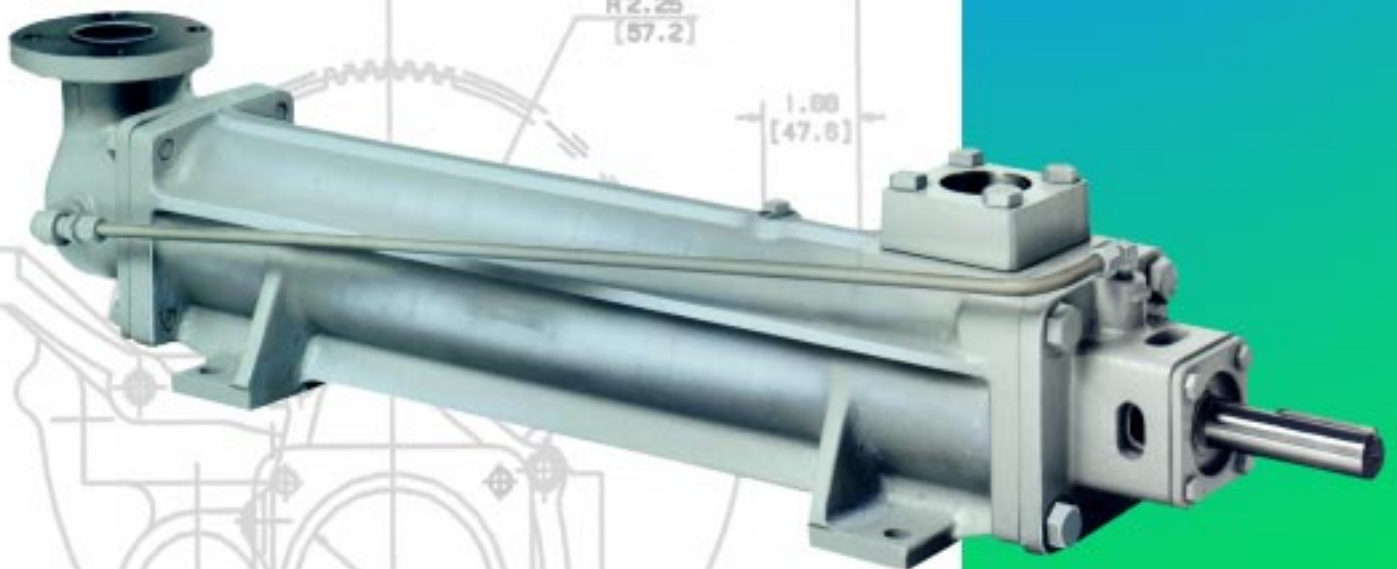

12D SERIES THREE SCREW PUMPS



ROTARY SCREW PUMPS

The reliable pump people

Performance Shown at 2000 PSID (138 BAR), 200 SSU (43 CST)

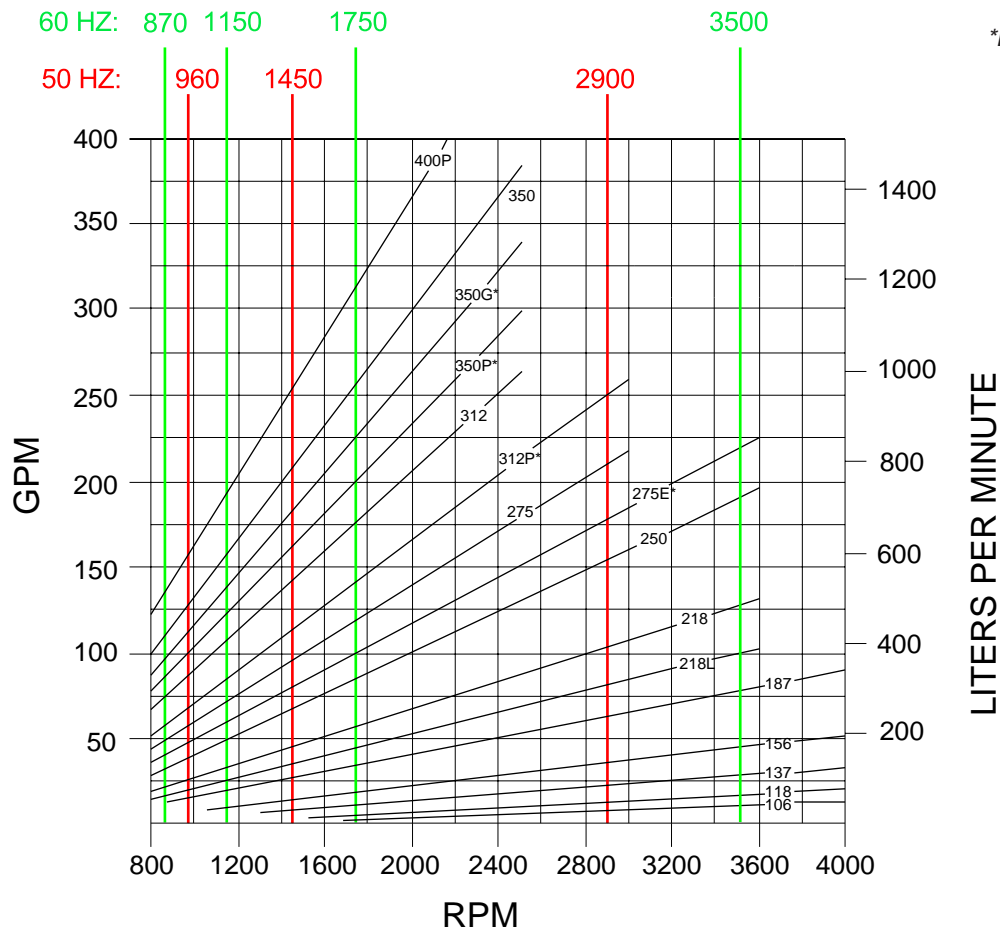

*Bi-metal construction only

On the cover...12D-218 pump typical for sizes 218-400 shown with standard (top) inlet position. Outlet socket weld adapter is included with pump.



12D-137 pump on compressor gas sealing service



12D-400P on crude oil pipeline service in Alberta, Canada at 1440 PSIG (99 BAR)



12D-218 on hydraulic service

Imo Series 12D Pump

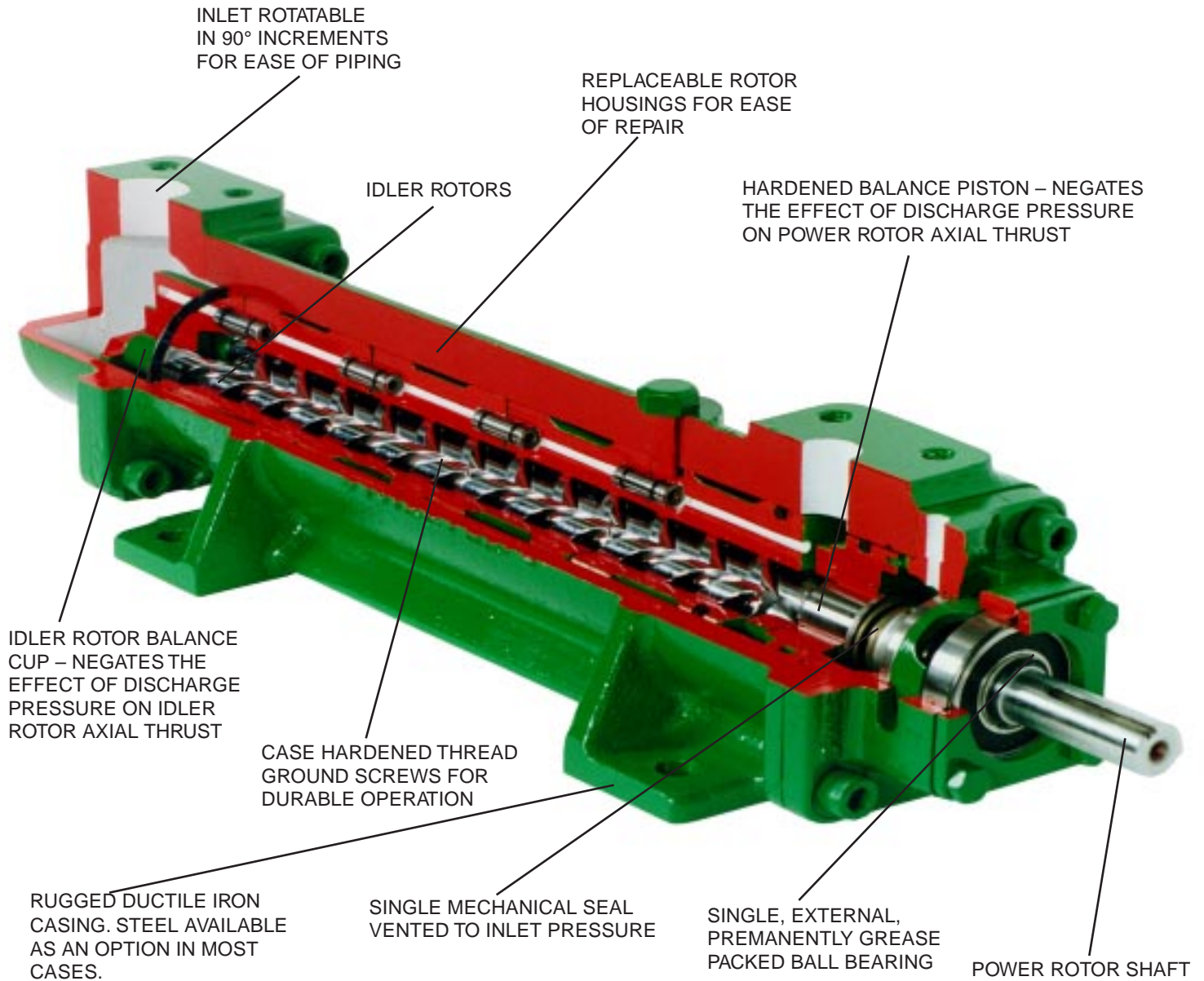

Shown above: 12D-118 typical of sizes 106 through 187

Specifications

Casing	High shock capacity ductile (nodular) iron. Cast steel optional, sizes 118-218
Rotor Housing	Pearlitic gray iron, sizes 106-187. Bronze, sizes 218-up. Special bimetallic housings available in some sizes for low viscosity, high pressure services.
Power Rotor	Alloy steel, nitride hardened and thread ground
Idler Rotors	Pearlitic gray iron, hardened and thread ground, sizes 106-187 Alloy steel, hardened and thread ground, sizes 218-up
Gaskets	Cellulose and non-asbestos fiber
Shaft Seal & Bearing	Type B: Buna N bellows mechanical seal, Buna N O-rings and standard external, permanently grease packed, deep groove ball bearing – recommended for distillate fuels and lubricating oil or hydraulic fluids. Type H: Positive drive mechanical seal, Viton O-rings and external high temperature, permanently grease packed, deep groove ball bearing.
Accessories	Completely mounted pump/driver assemblies with baseplates, ANSI RF spool pieces built to order are available.
Outlet Pressure	1500 PSIG (103 BAR) maximum for distillate & residual fuels and crude oils 2200 PSIG (152 BAR) for lube, seal and hydraulic fluids. Minimum recommended differential pressure is 40 PSI (2.8 BAR) when viscosity \geq 100 ssu.
Inlet Pressure	Type B & H: 75 PSIG (5 BAR) maximum, distillate fuel, lube- sizes 106-187 50 PSIG (3 BAR) maximum, distillate fuel, lube- sizes 218-400 Type H: 40 PSIG (2.7 BAR) maximum, residuals and crude oil- sizes 106-187 10 PSIG (0.7 BAR) maximum, residuals and crude oil- sizes 218-400
Viscosity	33 SSU (2.0 CST) minimum Type B: 3000 SSU (650 CST) maximum (consider cold start) Type H: Viscosities above 3000 SSU (650 CST)
Temperature	Type B: 0 to 180°F (-18° to 82°C) Type H: 0 to 250°F (-18 to 121°C)
Speed	See curve termination for maximum speed. Do not exceed 1800 RPM when pumping residual fuels or crude oil due to the presence of abrasives and contaminants.
Drive	Direct only. Magnetic drive also available to 200 HP at 3500 RPM.
Rotation	Clockwise facing pump shaft standard. Consult Imo for counterclockwise
Mounting	May be foot mounted in any orientation. Flange mounting optional for vertical installations.
Filtration	Inlet strainers are required to keep contaminants and abrasives out of the pump and must be selected in consultation with the strainer vendor to prevent pump starvation. Normally, 60 mesh (0.01 inch- 238 micron) for light and 1/8-3/16 inch (3-5mm) openings for heavy oils are recommended. Return line filters for closed loop systems also recommended.

5-300 GPM (19-1135 L/M) Pressure to 2200 PSIG (152 BAR)

Series 12D lmo pumps are intended for relatively high pressure service on petroleum or similar viscosity liquids. Typical applications include crude oil pipeline service, fuel atomization for burning in a steam boiler, fuel injection for combustion gas turbines, fluid power service on hydraulically operated machinery, gas sealing in centrifugal compressors and hydrostatic bearing support.

These pumps are hydraulically balanced in both the axial and radial directions which eliminates bearing loads due to discharge pressure. The single bearing is external to the liquid pumped and does not rely on the lubricating qualities of the pumped liquid. The single mechanical seal is exposed only to inlet pressure. Very low airborne noise levels are normal for lmo three screw positive displacement pumps as are high operating efficiencies and non-pulsating delivery of flow.

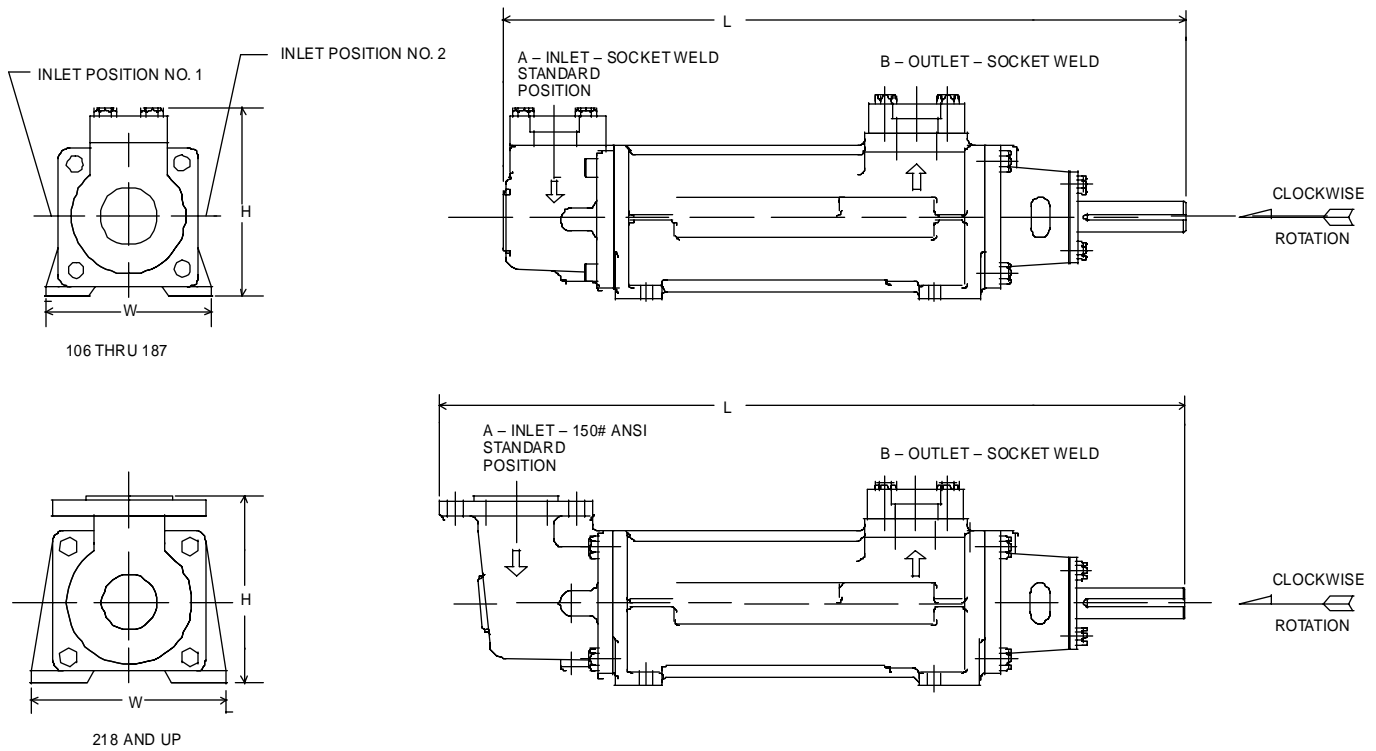

SIZE	A		B		H		L		W		WEIGHT	
	INCH	MM	INCH	MM	INCH	MM	INCH	MM	INCH	MM	LBS.	KG
106	1	25.4	1	25.4	6.8	171.5	25	635	6	152.4	71	32.2
118	1 1/2	38.1	1	25.4	7.0	177.8	26	660.4	6 1/4	158.8	85	38.5
137	1 1/2	38.1	1	25.4	7.3	184.2	30	760.4	6 1/2	165.1	103	46.7
156	2	50.8	1 1/2	38.1	7.8	196.9	34	863.6	7	177.8	140	63.5
187	2	50.8	1 1/2	38.1	8.3	209.6	38	965.2	8 1/2	215.9	193	87.5
218	2 1/2	63.5	2	50.8	9.5	241.3	50	1270.0	10	254.0	298	135.1
250	3	76.2	2 1/2	63.5	10.9	276.2	55	1397.0	11	279.4	408	185.0
275	3	76.2	3	76.2	12.3	311.2	59	1498.6	11	279.4	538	244.0
312	4	101.6	3	76.2	12.9	327.0	65	1651.0	12	304.8	649	294.3
350	5	127.0	3	76.2	15.2	385.8	72	1828.8	13	330.2	950	430.8
400*	6	152.4	4	101.6	19.2	487.7	74	1879.6	14	355.6	1125	510.2

DATA NOMINAL REQUEST CERTIFIED DRAWING FOR CONSTRUCTION

*1500# ANSI DISCHARGE

Imo Pump Sales Offices

Calgary

Imo Pump
5918 5th Street, S.E.
Unit 14
Calgary, Alberta
Canada T2H 1L4

tel 403.253.7491
fax 403.252.9833

New Orleans

Imo Pump
2637 Edenborn Avenue
Suite 304
Metairie, LA 70002

tel 504.888.3333
fax 504.888.3337

Houston

Imo Pump
11811 N. Freeway
Suite 190
Houston, TX 77060

tel 281.448.1337
fax 281.445.2316

Toronto

Imo Pump
6750 Davand Drive
Units 9/209
Mississauga, Ontario
Canada L5T 1L8

tel 905.564.3344
fax 905.564.3577

Philadelphia

Imo Pump
515 Stump Road
Suite 222
North Wales, PA 19454

tel 215.393.7400
fax 215.393.7622



Quality Management System



Imo Pump
1710 Airport Road
PO Box 5020
Monroe, NC USA
28111.5020

tel 704.289.6511
fax 704.289.9273
email IMOPUMP@VNET.NET
web WWW.IMO-PUMP.COM