

Solutions for Fluid Technology



**LEF**

空气除湿过滤器

DESICCANT BREATHERS

## 产品说明/应用范围

- 罐内通风吸潮和注入空气的净化都在同一个仪器内
- 干燥剂可更换并可单独提供干燥剂材料“EG”
- 干燥剂可以生活垃圾进行处理
- 按照 欧洲共同体发布指令99/45 EC和 2001/60EC不含任何有害物质
- 干燥剂性能检测简单，通过颜色由红色变为橙色判断
- 过滤器滤芯更换简单方便
- 液压系统内的氧化反应减小
- 油和设备的使用寿命延长
- 连接板“A”和粉尘显示“VA” 可组合供货

## PRODUCT DESCRIPTION/ APPLICATION RANGE

- Tank breathing, humidity absorption and cleaning of inflowing air in one unit
- Refillable with separate available desiccant “EG”
- Easy waste disposal of desiccant
- No content of any hazardous material acc. to EC directive 99/45/EC and 2001/60EC
- Easy capacity control of the desiccant by colour changing from red to orange
- Easy replacement of the airfilter cartridge
- Reduction of oxidation inside the hydraulic unit
- Service life extension of oil and machinery
- Available incl. adapter plates “A” and dust indication “VA”

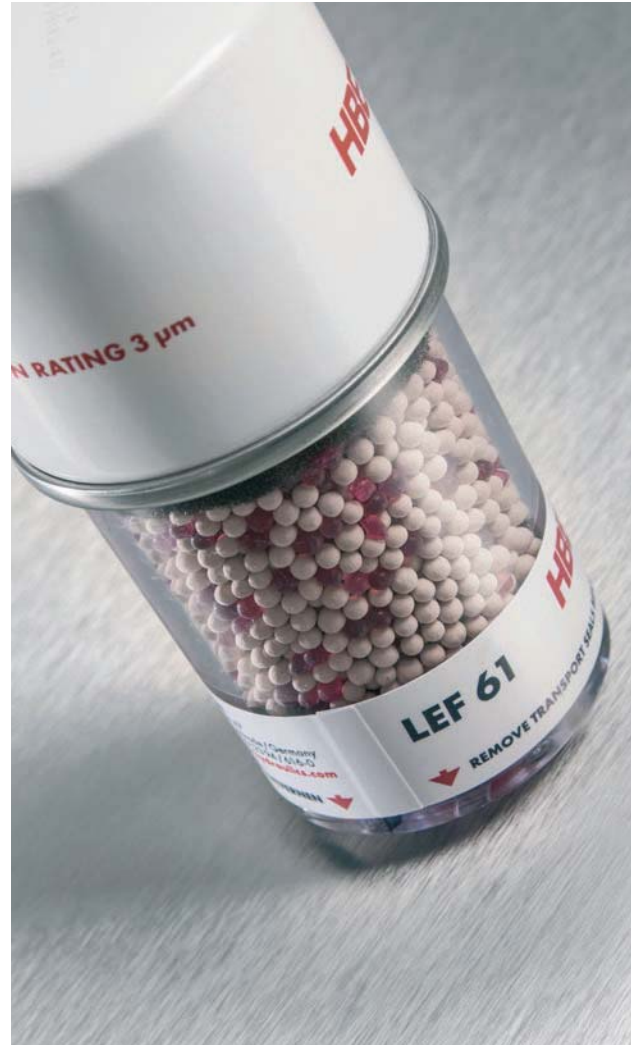

		空气除湿过滤器 Desiccant breathers				
型号 Type code	LEF 61	LEF 93	LEF 96	LEF 121	LEF 122	
产品代码 Order code	2700	2701	2702	2703	2704	
长度1/L1	136 mm	160 mm	220 mm	256 mm	366 mm	
长度2/L2	无/without	20 mm	20 mm	28 mm	28 mm	
直径/D	70 mm	98 mm	98 mm	130 mm	130 mm	
G	3/8" (I)	G 3/4"	G 3/4"	G 1 1/4"	G 1 1/4"	
SW	无/without	32 mm	32 mm	50 mm	50 mm	
最大空气流 max. Airflow	0.05 立方/分钟 0.05 m <sup>3</sup> /min	0.7 立方/分钟 0.7 m <sup>3</sup> /min	0.7 立方/分钟 0.7 m <sup>3</sup> /min	1.5 立方/分钟 1.5 m <sup>3</sup> /min	1.5 立方/分钟 1.5 m <sup>3</sup> /min	
过滤器过滤精度 Airfilter mesh	3 μm	3 μm	3 μm	3 μm	3 μm	
最大吸水量 max. Water absorption	29 克 29 g	86 克 86 g	172 克 172 g	288 克 288 g	576 克 576 g	
推荐容量 Recommended tank size	< 30 立升 < 30 l	< 250 立升 < 250 l	< 500 立升 < 500 l	< 1250 立升 < 1250 l	> 1250 立升 > 1250 l	
工作温度 Operating temperature	./ 40° .... + 90°C	./ 40° .... + 90°C	./ 40° .... + 90°C	./ 40° .... + 90°C	./ 40° .... + 90°C	
重量 Weight	0.4 公斤 0.4 kg	1.2 公斤 1.2 kg	1.5 公斤 1.5 kg	2.7 公斤 2.7 kg	4.0 公斤 4.0 kg	

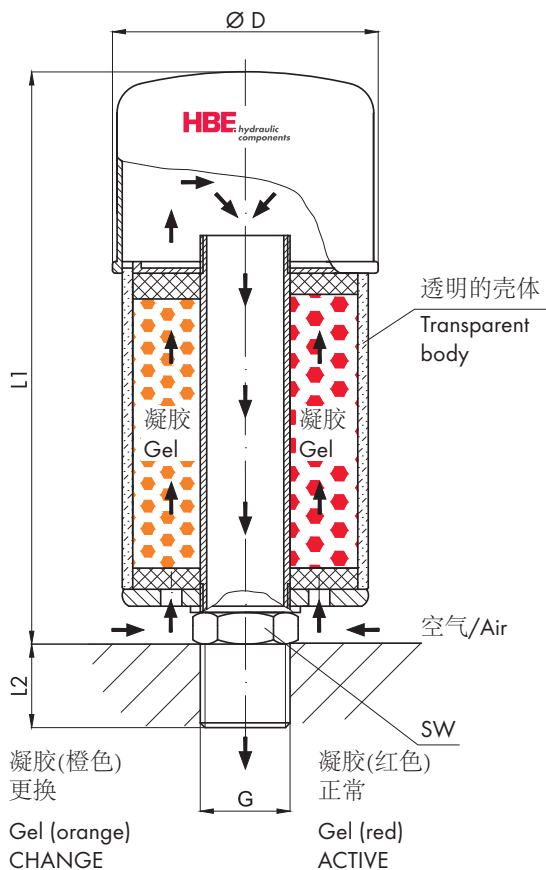
**材料**

- 内管: 不锈钢
- 壳体: 苯乙烯塑料
- 吸潮材料: 溶凝胶体 (3 - 6毫米)

**可兼容液体**

- 矿物油
  - H, HL, HLP, HVLP: OK
  - HEES (Synt. Ester): OK
- 其它液体请咨询HBE

**MATERIALS**

- Inner Tube: Stainless Steel
- Body: SAN (Styrol Acrylnitril)
- Desiccant: ZR-Gel (3 - 6 mm)

**FLUID COMPATIBILITY**

- Mineral Oil: OK
  - H, HL, HLP, HVLP: OK
  - HEES (Synt. Ester): OK
- for other fluids please contact HBE

	附件 Spare parts				
空气过滤芯件 Air filter cartridge	LF 6	LF 9	LF 9	LF 12	LF 12
产品代码 Order code	2710	2711	2711	2713	2713
干燥胶E Desiccant kit	EG 6	EG 93	EG 96	EG 121	EG 122
产品代码 Order code	2720	2721	2722	2723	2724
	可选配件 Optional accessories				
安装板 Adapter plate	不可选/not available	A 9	A 9	A 12	A 12
产品代码 Order code	不可选/not available	2731	2731	2733	2733
粉尘显示 Dust indicator	不可选/not available	VA	VA	VA	VA
产品代码 Order code	不可选/not available	2741	2741	2741	2741

## 附件

## 粉尘显示器 “VA”

连接板上已设有一个为安装粉尘显示器“VA”的连接孔，“VA”用于显示过滤芯污染程度情况。

更换过滤芯元件“LF”后，按下RESET键即可恢复显示重新启用。

## ACCESSORIES

## DUST INDICATOR “VA”

The adapter plates include a bore for the connection of an optical dust indicator “VA” which is displaying the contamination level of the airfilter.

After changing the airfilter cartridge “LF”, the dust indicator is re-useable by pressing the RESET button.

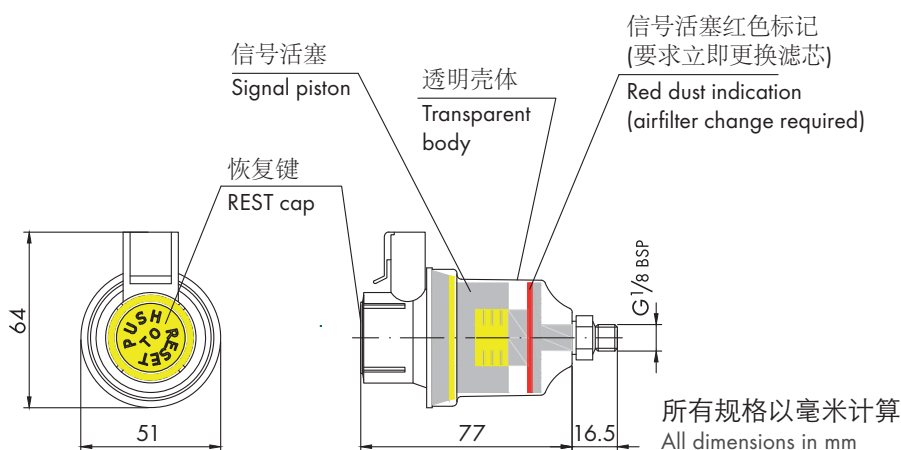

## 附件

### 连接板“A”

塑料连接板“A”已配有连接，除湿器可直接连接安装。

插头，O形圈和六角螺栓都包括在发货范围内。

### 规格

型号 Type	A9	A12
D	88 mm	100 mm
H	50 mm	70 mm
G	G 3/4"	G 1 1/4"



本目录手册的出版使此前出版的版本全部数据失效。德国HBE保留变更权利。德国HBE对可能出现的印刷错误不承担责任。复制，包括摘录只能通过HBE书面申请获得授权。德国HBE保留任何时候对技术信息进行修改的权利。最新版本 12/2017

## ACCESSORIES

### ADAPTER PLATES "A"

The plastic adapter plates "A" allow a direct assembly of the LEF desiccant breathers on existing connections.

Plug, O-Ring and head cap screw are included.

### DIMENSIONS

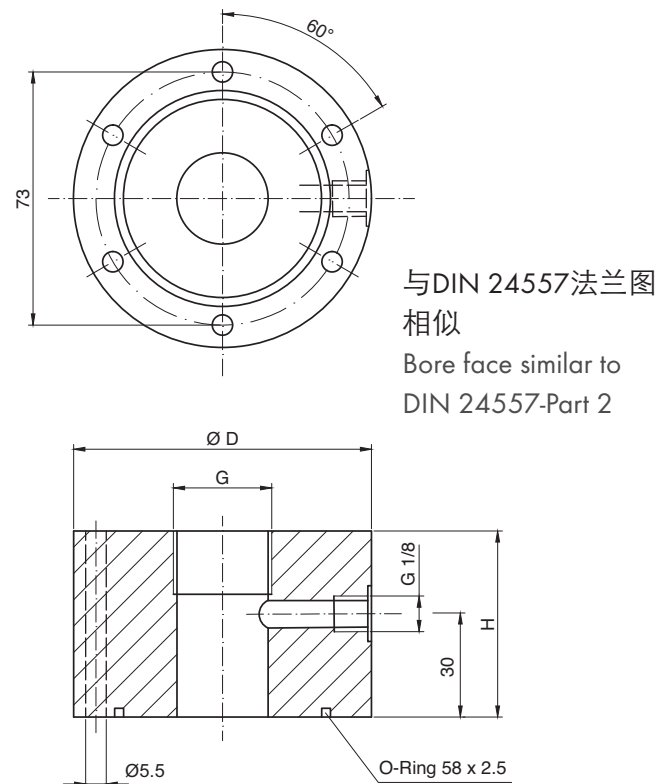

The current publication of this catalogue supersedes all information from previous publications. HBE reserves the right to make changes and substitutions. HBE is not liable for any printing errors. Reproduction, including excerpts, is permitted only after written approval by HBE. HBE reserves the right to modify technical data at any time. Last revised: 12/2017



上海新洁流体科技有限公司  
联系人：袁建红 经理  
电话：13918089112  
邮箱：yuanjianhong@vip.sina.com



**e.holding**  
FLUID TECHNOLOGY GROUP  
[www.e-holding.de](http://www.e-holding.de)